

Agri+Fab™

**OWNERS
MANUAL**

**Model No.
45-0404**



**HEAVY DUTY
POLY DUMP CART**

CAUTION:
Read Rules for
Safe Operation
and Instructions
Carefully

- Assembly
- Operation
- Maintenance
- Repair Parts

SpeedEPart *the fastest way to purchase parts* www.speedepart.com

SAFETY RULES

Remember, any power equipment can cause injury if operated improperly or if the user does not understand how to operate the equipment. Exercise caution at all times when using power equipment.



LOOK FOR THIS SYMBOL TO POINT OUT IMPORTANT SAFETY PRECAUTIONS. IT MEANS — ATTENTION! BECOME ALERT! YOUR SAFETY IS INVOLVED.



CAUTION: VEHICLE BRAKING AND STABILITY MAY BE AFFECTED WITH THE ADDITION OF AN ACCESSORY OR AN ATTACHMENT. BE AWARE OF CHANGING CONDITIONS ON SLOPES.

Exercise caution at all times when using power equipment.

- Read this owners manual before attempting to assemble or operate the cart.
- Read the vehicle owners manual and know how to operate your vehicle before using the cart attachment.
- Do not at any time carry passengers in this cart. It has not been designed to carry passengers.
- Never allow children to operate the vehicle or the cart attachment.
- Do not allow adults to operate the vehicle or cart attachment without proper instructions.
- Always begin with the transmission in first (low) and gradually increase speed as conditions permit.
- Tow the cart at reduced speed over rough terrain and hillsides or near creeks and ditches to prevent tipping over and loss of control. Do not drive too close to a creek or ditch.
- Vehicle braking and stability may be affected with the attachment of this cart. Do not fill cart to maximum weight capacity without checking the capability of the towing vehicle to safely pull and stop with the cart attached.
- Before operating vehicle on any grade (hill) refer to the safety rules in the vehicle owner's manual concerning safe operation on slopes. Refer also to the slope guide on page 11 of this manual. **Stay off steep slopes!**
- Do not tow this cart on highways or on public thoroughfares.
- Maximum towing speed is 10 m.p.h.
- Follow maintenance and lubrication instructions as outlined in this manual.

CARTON CONTENTS (Loose Parts)

- | | | |
|------------------------|--------------------|---------------------|
| 1. Poly Tray | 5. Axle | 8. Latch Lock Lever |
| 2. Wheel Support | 6. Wheels (2) | 9. Hitch Bracket |
| 3. Latch Stand Plate | 7. Draw Bar Tongue | |
| 4. Latch Stand Bracket | | |

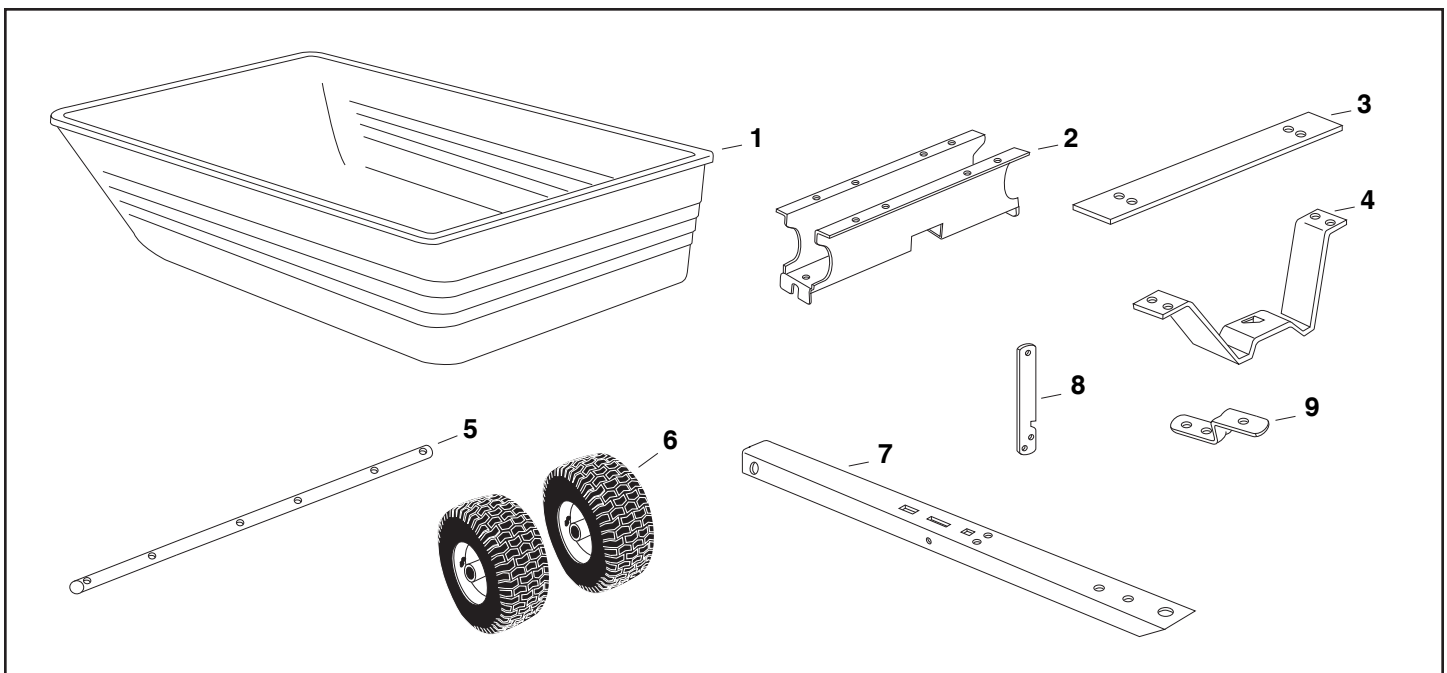

CARTON CONTENTS

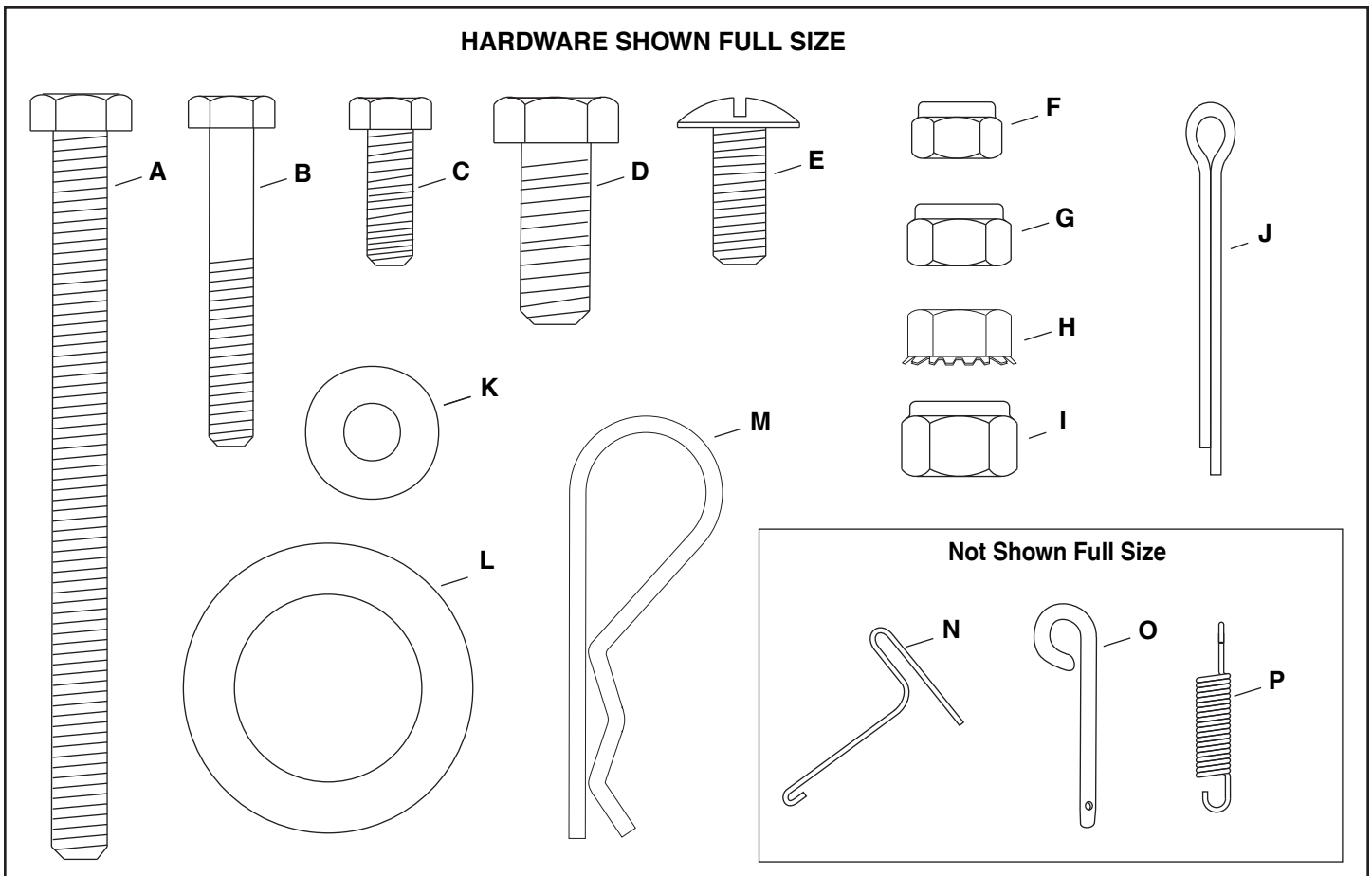

HARDWARE PACK

REF.	QTY.	DESCRIPTION	REF.	QTY.	DESCRIPTION
A	1	Hex Bolt, 5/16" x 4"	I	2	Nylock Nut, 3/8"
B	4	Hex Bolt, 1/4" x 1-3/4"	J	2	Cotter Pin, 1/8" x 1-1/2"
C	4	Hex Bolt, 1/4" x 3/4"	K	4	Flat Washer, 1/4"
D	2	Hex Bolt, 3/8" x 1"	L	4	Flat Washer, 1"
E	8	Truss Head Bolt, 5/16" x 3/4"	M	1	Hair Cotter Pin
F	8	Nylock Nut, 1/4"	N	1	Spring Puller Tool
G	9	Nylock Nut, 5/16"	O	1	Hitch Pin
H	2	(SEMS) Nut, 5/16"	P	1	Extension Spring

ASSEMBLY INSTRUCTIONS

TOOLS REQUIRED FOR ASSEMBLY

- (1) Screwdriver
- (1) Pliers
- (2) 7/16" Wrenches
- (2) 1/2" Wrench
- (2) 9/16" Wrenches

1. Remove the hardware pack and all loose parts from the carton. Be sure the carton is empty before discarding.
2. Lay out and identify all the parts and hardware as shown on pages 2 and 3.
3. Place the latch lock lever through the slot in the draw bar tongue as shown in figure 1. Assemble the 5/16" x 4" hex bolt through the tongue, the lever and two 5/16" (SEMS) nuts (one on each side of the lever). Assemble a 5/16" nylock nut onto the end of the bolt and **tighten** so that the bolt can still rotate freely. **Tighten** the two 5/16" (SEMS) nuts against the sides of the latch lock lever so that the lever is centered in the slot. See figure 1.

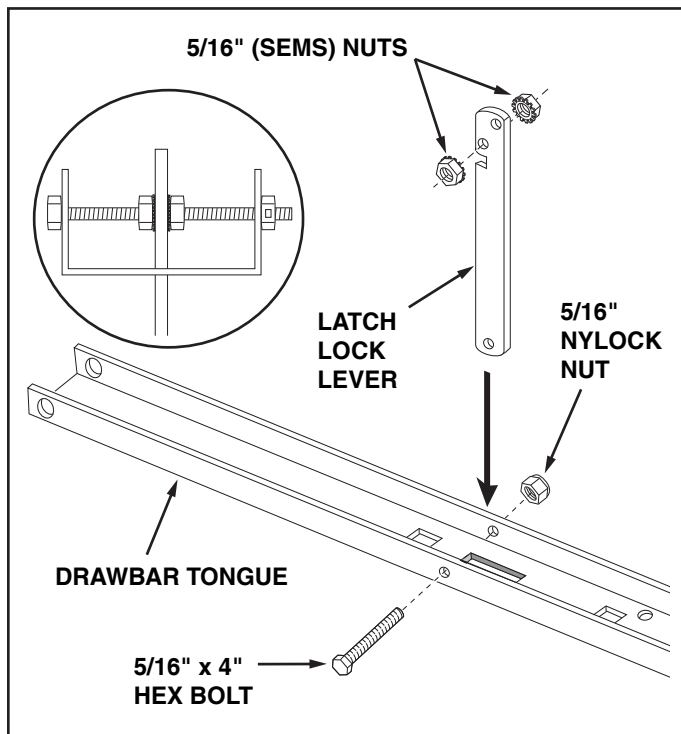

FIGURE 1

4. Hook the **short** end of the spring into the hole in the latch lock lever. Use the spring puller tool to hook the **long** end of the spring into the square hole in the tongue. The spring puller tool can be stored when finished. See figure 2.

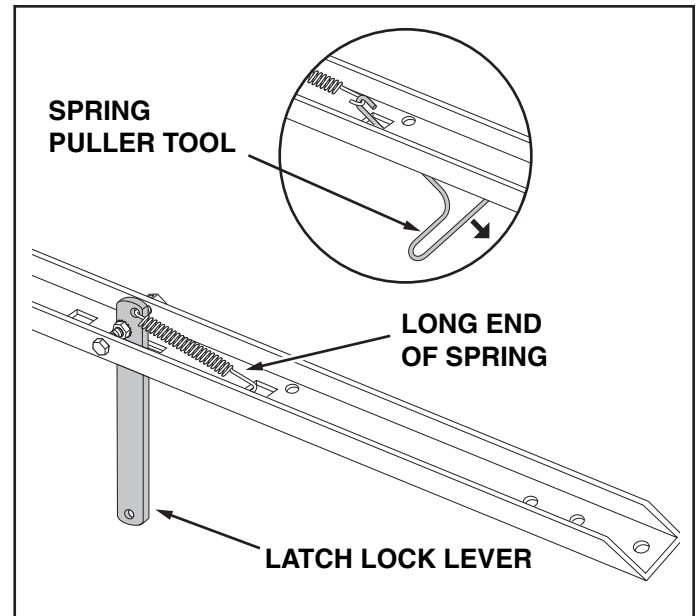

FIGURE 2

5. Assemble the hitch bracket to the drawbar tongue using two 3/8" x 1" hex bolts and 3/8" nylock nuts. **Tighten**. See figure 3.
6. Assemble the hitch pin to the tongue and hitch bracket and secure it with the hair cotter pin. See figure 3.

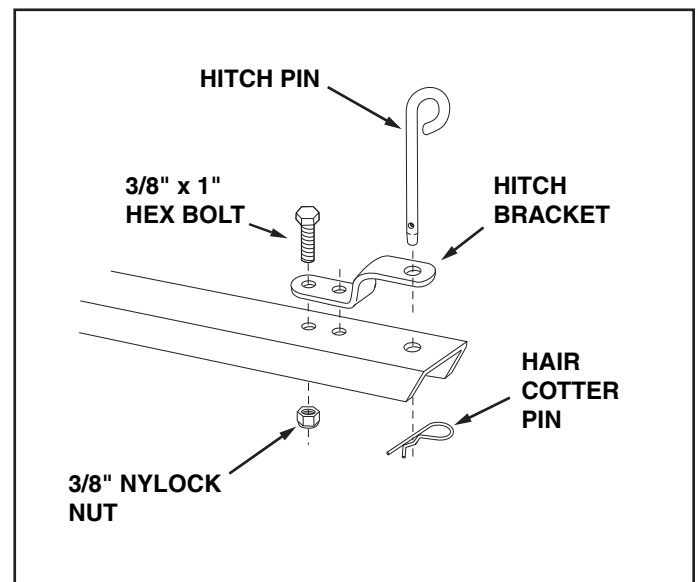

FIGURE 3

7. Assemble the axle and drawbar tongue to the wheel support, with the open side of tongue facing away from the wheel support. Fasten the axle to the wheel support using four 1/4" x 1-3/4" hex bolts and 1/4" nylock nuts. **Tighten.** See figure 4.

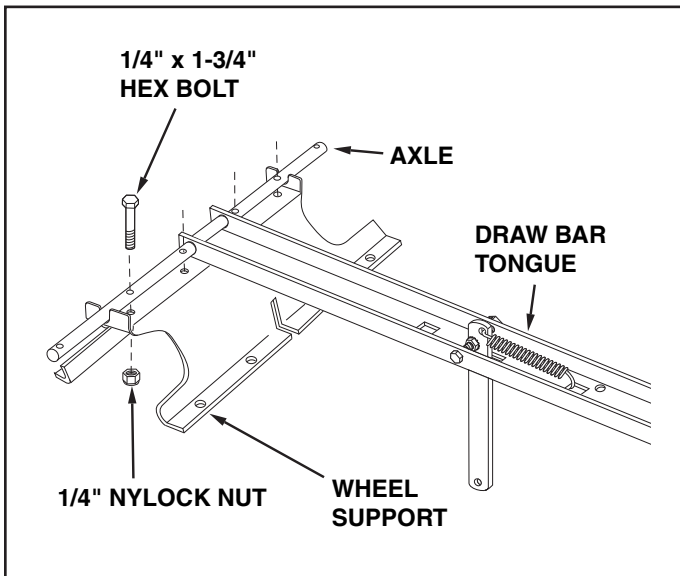

FIGURE 4

8. Assemble a 1" flat washer, a wheel (valve stem facing out) and another 1" flat washer onto the axle as shown in figure 5. Insert a cotter pin through the axle, spreading the ends. Repeat on other end of axle.

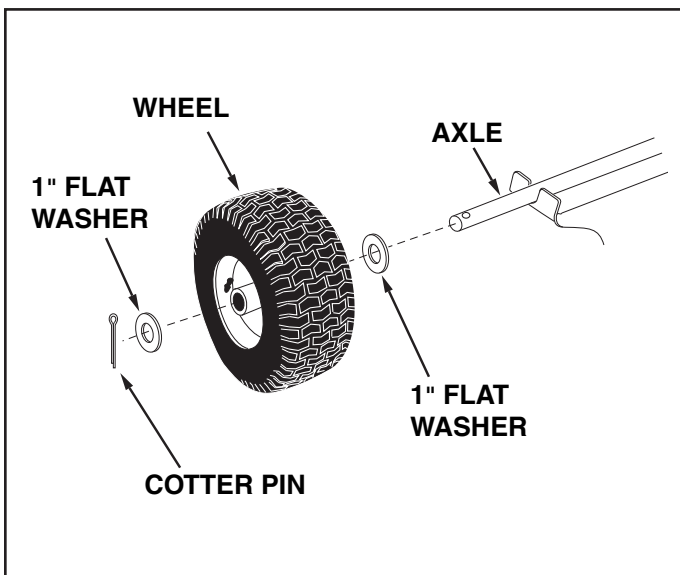

FIGURE 5

9. Assemble the latch stand plate and the latch stand bracket to the bottom of the poly tray using four 1/4" x 3/4" hex bolts, 1/4" flat washers and 1/4" nylock nuts. The aligning tab on the bottom of the latch stand bracket must be towards the rear of the cart. **Tighten.** See figure 6.

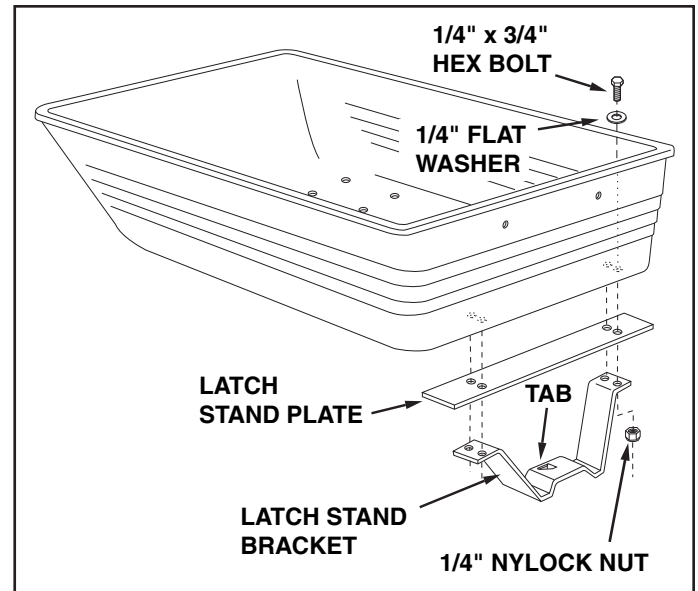

FIGURE 6

10. Place the poly tray down onto the wheel support, positioning it so that the latch stand bracket snaps under the latch lock lever. Fasten the tray to the wheel support using eight 5/16" x 3/4" truss head bolts and 5/16" nylock nuts as shown in figure 7. **Tighten.**

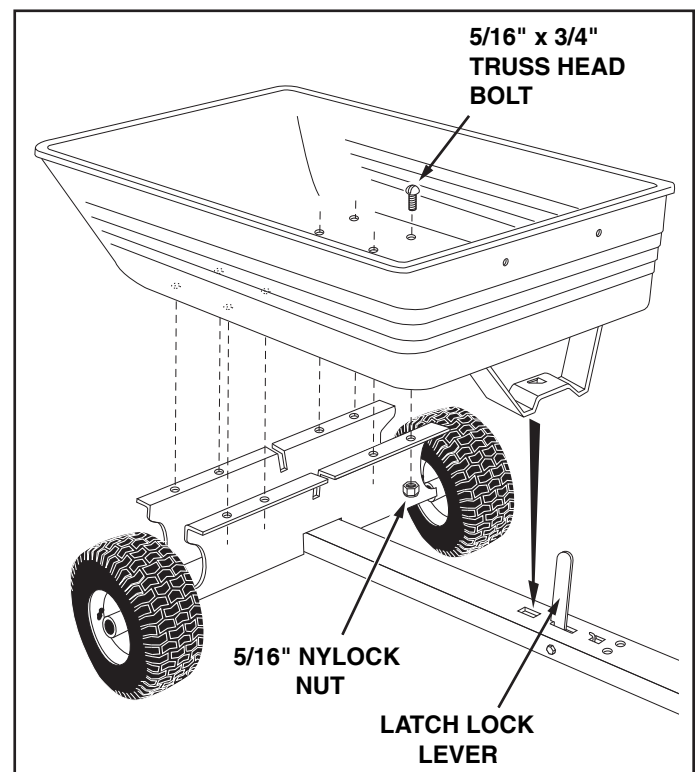

FIGURE 7

OPERATION



CAUTION: VEHICLE BRAKING AND STABILITY MAY BE AFFECTED WITH THE ADDITION OF AN ACCESSORY OR AN ATTACHMENT. BE AWARE OF CHANGING CONDITIONS ON SLOPES.

1. Refer to the vehicle owners manual for instructions on safe operation on slopes.
2. Use the slope guide provided on page 11 of this manual to determine whether slope angle is too steep for safe operation.
3. For best handling and traction, distribute the weight of the load evenly in the cart.
4. Always test to make sure your vehicle has adequate towing and braking capabilities whenever hauling a substantial amount of weight in your cart. Use extra caution when operating on slopes.



NOTE

DO NOT EXCEED WEIGHT CAPACITY OF CART

(See the specifications on this page.)

One cubic foot of dirt weighs approximately 80 lbs.

5. To dump material from the cart, release the spring latch on the tongue by pulling the latch lock lever forward, away from the cart. The cart bed will then tilt backwards to empty its contents. After emptying, pull the front of the bed down toward the cart tongue until the latch snaps into place.
6. The maximum towing speed for this cart is 10 m.p.h.



CAUTION: TO AVOID POSSIBLE INJURY, BEFORE RELEASING THE LATCH BE SURE THAT NO ONE IS NEAR THE CART.

MAINTENANCE

1. At the beginning of each season, using a light machine oil, lubricate the latch, the latch pivot bolt, and the area of the axle where the draw bar tongue pivots .
2. At the beginning of each season, grease or oil the wheel bearings.
3. Check periodically for loose bolts.
4. Keep tires filled. Do not exceed maximum tire pressure printed on tires.

CART SPECIFICATIONS

Tires: 15" x 6" Pneumatic
Axle: 1" Dia. Steel
Capacity: Up to 750 Lbs. Max.

NOTES

REPAIR PARTS FOR HEAVY DUTY POLY DUMP CART MODEL 45-0404

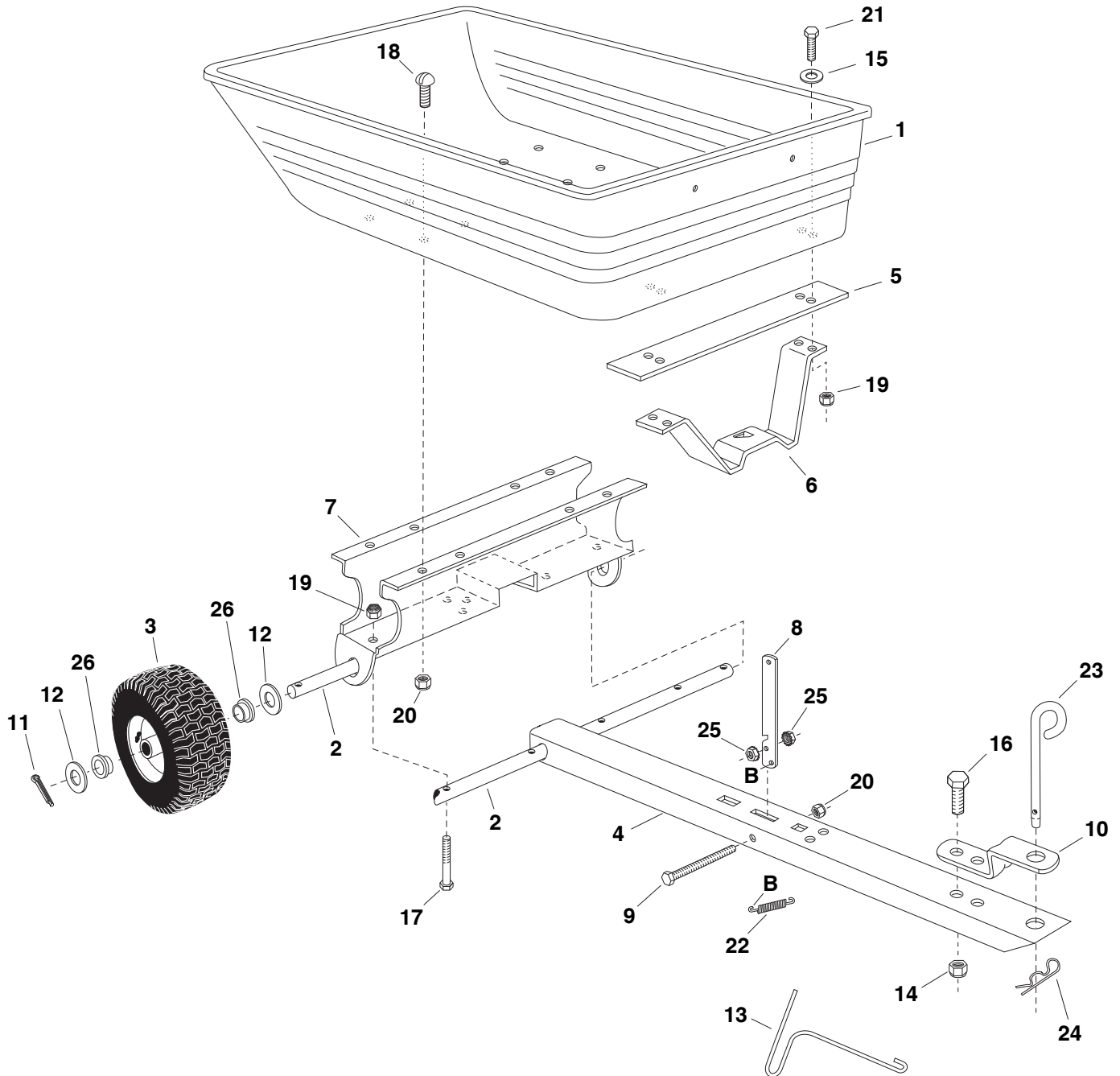

REPAIR PARTS FOR HEAVY DUTY POLY DUMP CART MODEL 45-0404

REF. NO.	PART NO.	QTY.	DESCRIPTION
1	47019	1	Poly Tray
2	25886	1	Axle, 1"
3	46272	2	Wheel
4	24758	1	Draw Bar Tongue
5	24386	1	Latch Stand Plate
6	24497	1	Latch Stand Bracket
7	24527	1	Wheel Support
8	24498	1	Latch Lock Lever
9	47407	1	Hex Bolt, 5/16-18 x 4"
10	23014	1	Hitch Bracket
11	43093	2	Cotter Pin, 1/8" x 1-1/2"
12	43601	4	Washer, Flat 1.59" O.D. x 1" I.D.
13	47622	1	Spring Puller
14	HA21362	1	Nylock Nut, 3/8-16*
15	43088	4	Flat Washer, 1/4"
16	43001	2	Hex Bolt, 3/8-16 x 1" *
17	1509-69	4	Hex Bolt, 1/4-20 x 1-3/4" *
18	43814	8	Truss Head Bolt, 5/16-18 x 3/4"
19	47189	8	Nylock Nut, 1/4-20
20	47810	9	Nylock Nut, 5/16-18
21	43012	4	Hex Bolt, 1/4-20 x 3/4" *
22	47408	1	Extension Spring
23	23353	1	Hitch Pin
24	43343	1	Hair Cotter Pin, 3/32"
25	46980	2	Hex Nut (SEMS), 5/16-18
26	44488	4	Wheel Bearing
	40146	1	Owner's Manual

* Purchase Common Hardware Locally

SpeedEPart *the fastest way to purchase parts* www.speedepart.com

For Agri Fab Discount Parts Call 606-678-9623 or 606-561-4983

SLOPE GUIDE

(Keep this sheet in a safe place for future reference.)

Use this guide to determine if a slope is safe for the operation of your tractor and cart. Refer also to the instructions in your vehicle owners manual.

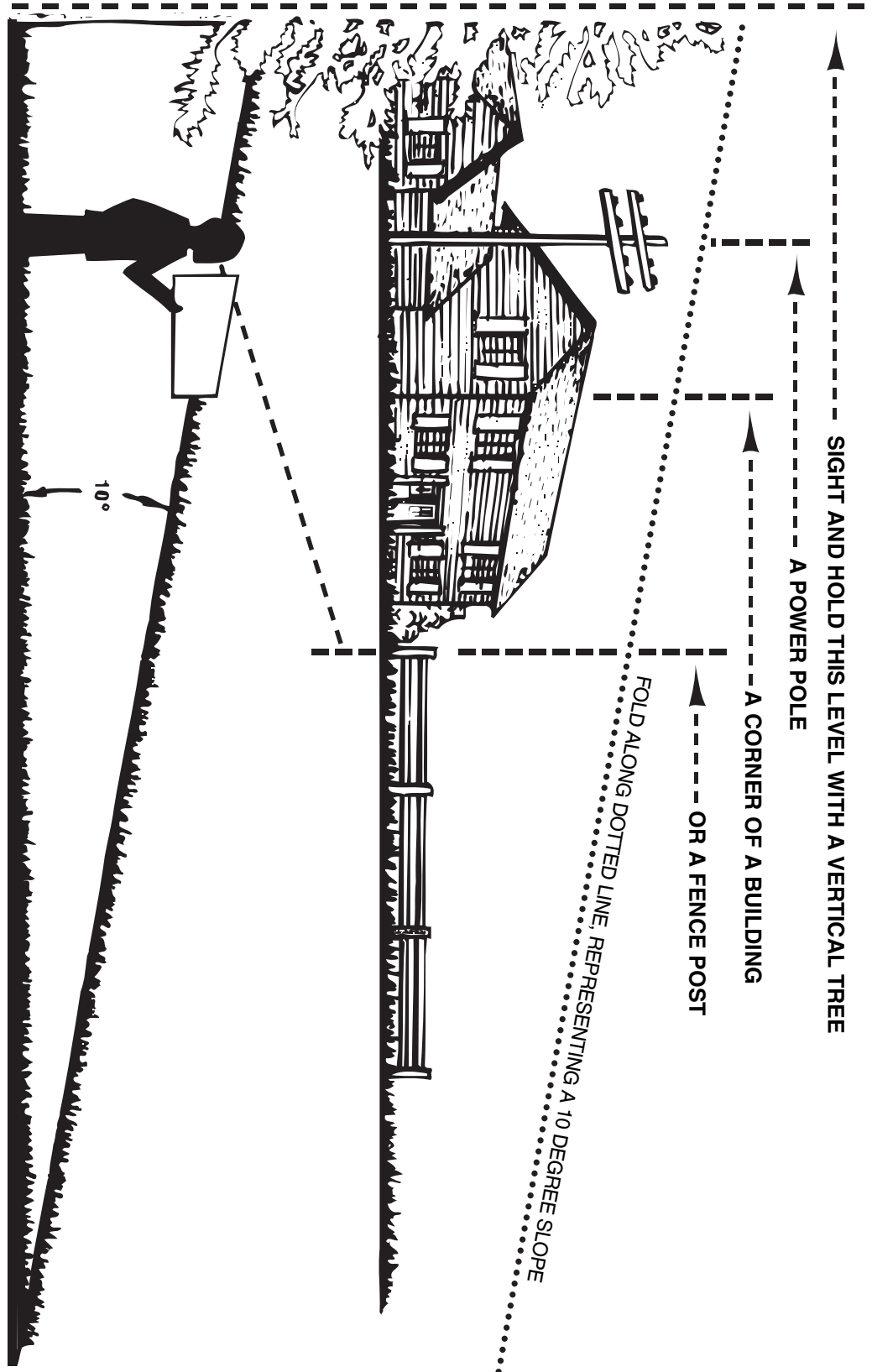

CAUTION: DO NOT OPERATE YOUR TRACTOR AND CART ON A SLOPE IN EXCESS OF 10 DEGREES. BE SURE OF YOUR TRACTOR'S TOWING AND BRAKING CAPABILITIES BEFORE OPERATING ON A SLOPE. AVOID ANY SUDDEN TURNS OR MANEUVERS WHILE ON A SLOPE.

SpeedEPart *the fastest way to purchase parts* www.speedepart.com

REPAIR PARTS

Agri-Fab, Inc.
809 South Hamilton
Sullivan, IL. 61951
217-728-8388
www.agri-fab.com

This document (or manual) is protected under the U.S. Copyright Laws and the copyright laws of foreign countries, pursuant to the Universal Copyright Convention and the Berne convention. No part of this document may be reproduced or transmitted in any form or by any means, electronic or mechanical, including photocopying or recording, or by any information storage or retrieval system, without the express written permission of Agri-Fab, Inc. Unauthorized uses and/or reproductions of this manual will subject such unauthorized user to civil and criminal penalties as provided by the United States Copyright Laws.